

FLEX2000 BUTTON MACHINE

USER MANUAL



people power press

button machines • button parts • custom buttons

ANATOMY OF YOUR FLEX2000

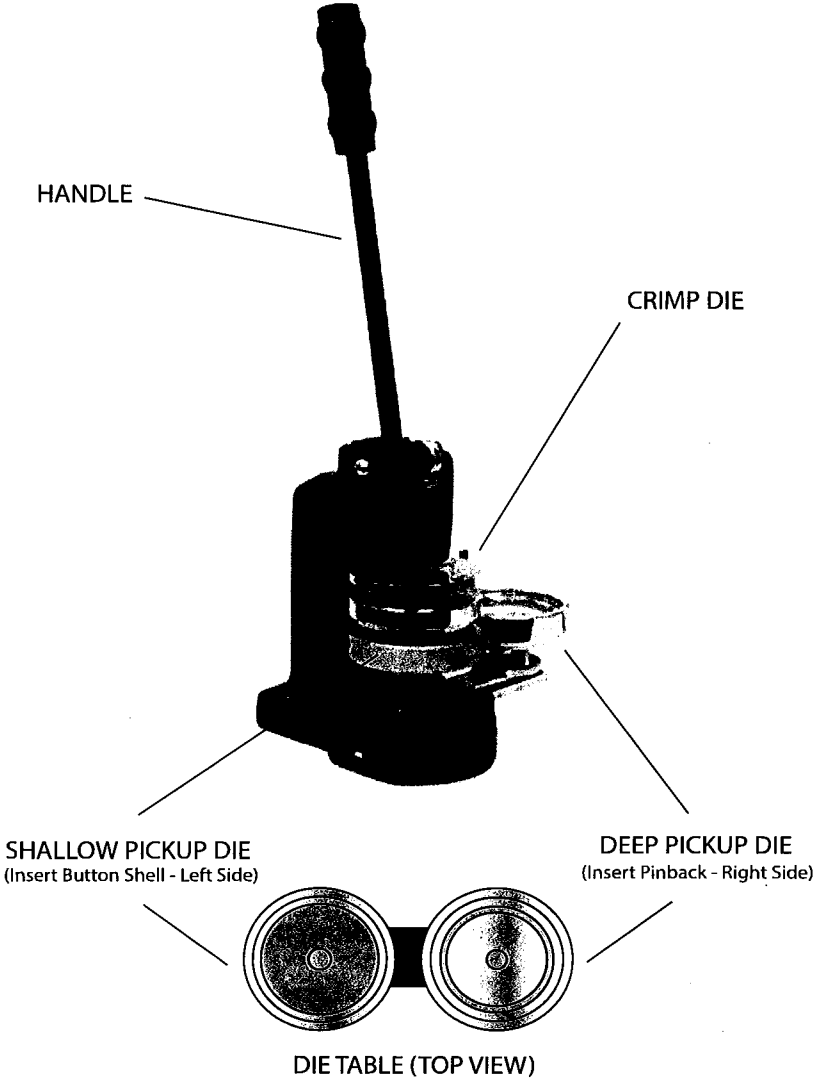

TO MAKE A BUTTON YOU WILL NEED:



- 1. Button Press
- 2. Die Set a) Shallow Pickup Die*
b) Deep Pickup Die*
c) Crimp Die*
- 3. Plastic Insert Ring (for some of the add-on sizes)

*Every button size requires it's own **DIE SET** (shallow pickup die, deep pickup die and crimp die). Be sure to keep your die sets organized and use parts/supplies of the same size.

Pinback button making parts:

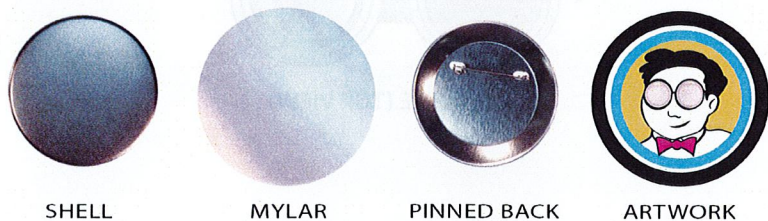

CHANGING THE DIE SET:

A. Removing the dies:

- A1. To swap the **die set**: Remove the **pickup dies** first. Slide the die table all the way to the right side and simply lift out the shallow pickup die. Repeat on the left to remove the deep pickup die.
- A2. Once both pickup dies have been removed, hold the **crimp (top) die** firmly and pull down. The pin holding it in place will slide out of the button press.

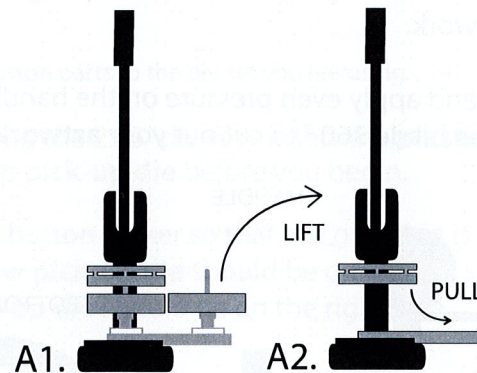

B. Replacing the dies:

- B1. First replace the crimp (top) die by sliding the post back into the button press.
- B2. Slot the pickup dies into the holes on either side of the die table. Make sure the shallow die is on the right and the deep die is on the left. Make sure that the small post on either side of the die table inserts into the hole at the base of the die.

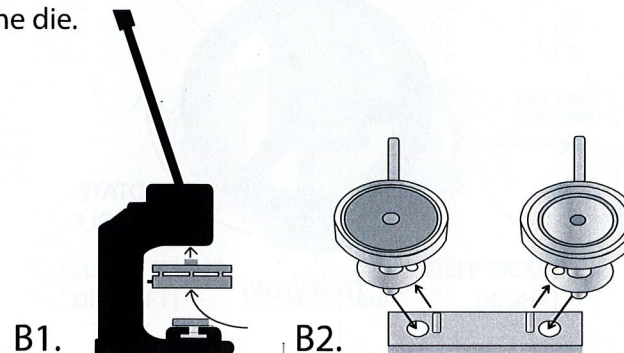

USING THE ROTARY CUTTER

1. Place your printed sheet of **artwork** on top of a cutting surface such as a cutting mat or board. Softer surfaces (like cutting mats) have more give and traction and will work better than harder surfaces (like glass)
2. Center the corresponding size **rotary cutter** on top your sheet of **artwork** and line up the blade with the edge of your printed artwork.
3. Push down and apply even pressure on the handle and rotate to rotate the blade 360° to cut out your **artwork**.

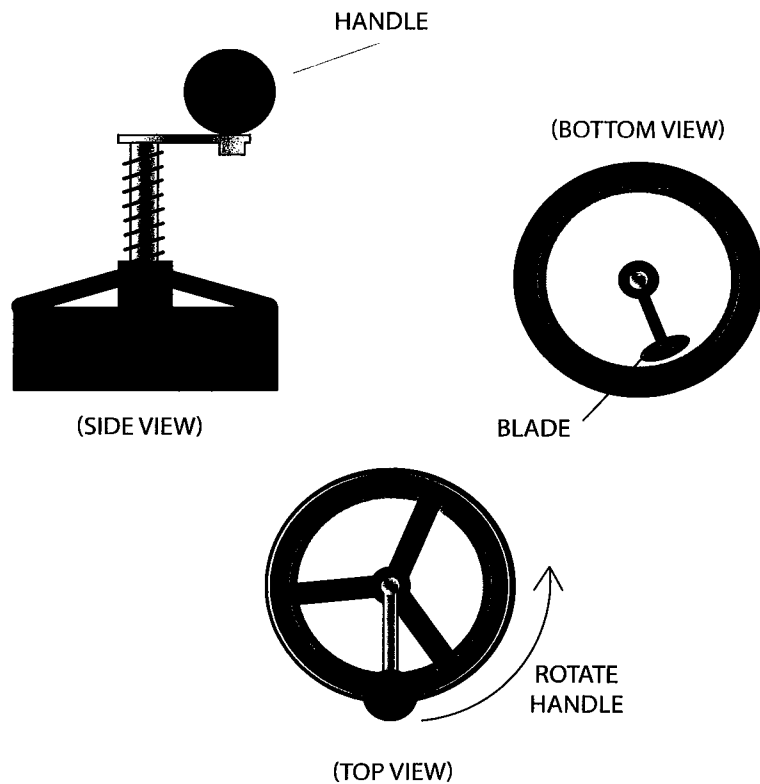

MAKING A BUTTON

Before you start:

Place the button maker in front of you, with the dies easily accessible, on a solid table so that the machine doesn't shift. You may want to use the holes in the base to secure your button maker onto a wooden board for added stability.

Make sure that the appropriate size of dies are inserted into the table and that the matching (top) **crimp die** has been slotted into place.

*Match your button parts to the die set you are using.

If you are using the 2.25" die set - insert the **plastic insert ring** into the **deep pick-up die** before you begin.

1. Set up the button maker so that the die table is facing you. The **shallow pick-up die** should be on the left side and the **deep pick-up die** should be on the right side.

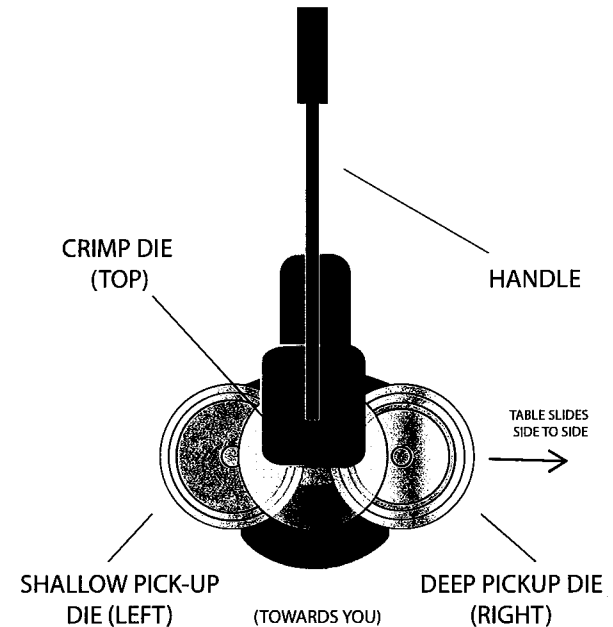

1. Get Your Button Parts Ready

- 1a. Place a **shell** in the **SHALLOW DIE (LEFT)** The edge of the **shell** slots into the round channel in the die. The **shell** should fit exactly into the slot.
- 1b. Place your cut-out **artwork** over the shell. It should fit snugly in the available space.
- 1c. Place a piece of **mylar** on top of your **artwork**.
- 1d. Place the **pinned-back** into the **DEEP PICKUP DIE (RIGHT)** it should sit snugly in the depression in the die. Make sure the pin is aligned the same way as your artwork. The hook and pin side of the back should be facing down.

*If you are making 2.25" buttons the white **plastic insert ring** must be placed in the deep pickup die before the pinned-back.

For best results, use the post on the back of the **dies to orient your artwork, if you point the top of your both artwork and the top of your pinned back towards these posts your buttons will come out right side up!

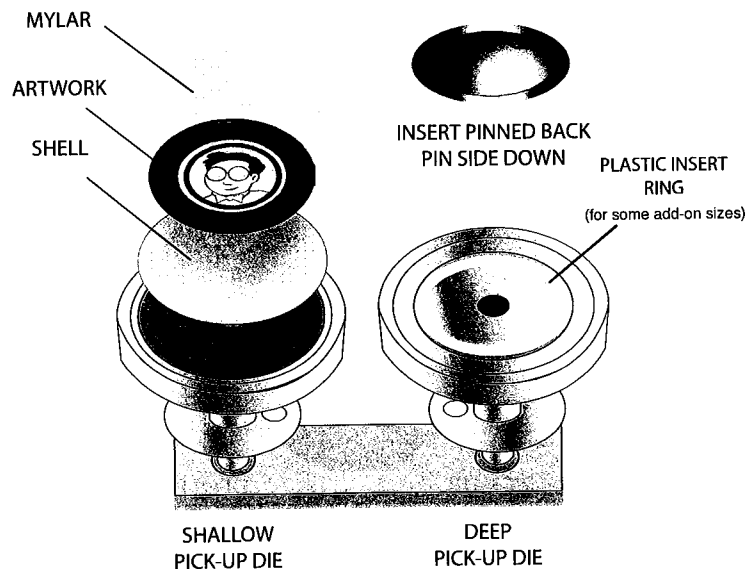

2. Pressing the button (step 1):

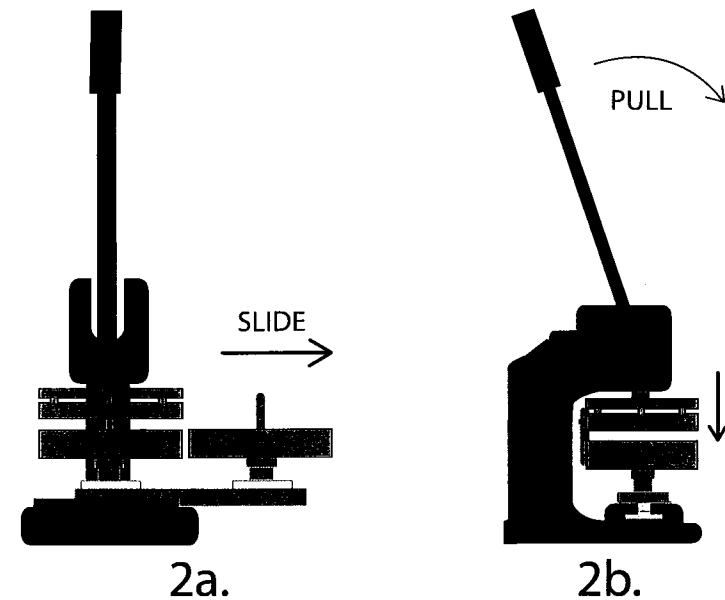

2a. Slide the **die table** all the way to the right so that the **shallow pick-up die** (with your shell and artwork in it) is centered under the press. The die should align with the **crimp die** (top).

2b. With the die table facing you, pull the handle down towards you. You will note with the first press that you feel the die depress as it picks up your button. No force is necessary, just pull the handle down as far as it goes.

3. Pressing the button (step 2):

- 3a. Slide the **die table** all the way to the left so that the **deep pick-up die** with your pinned back in it, is centered under the press. The die should align with the **crimp die** (top).
- 3b. Pull the handle down towards you like before. It will not pull down as far as it did during the first pressing.

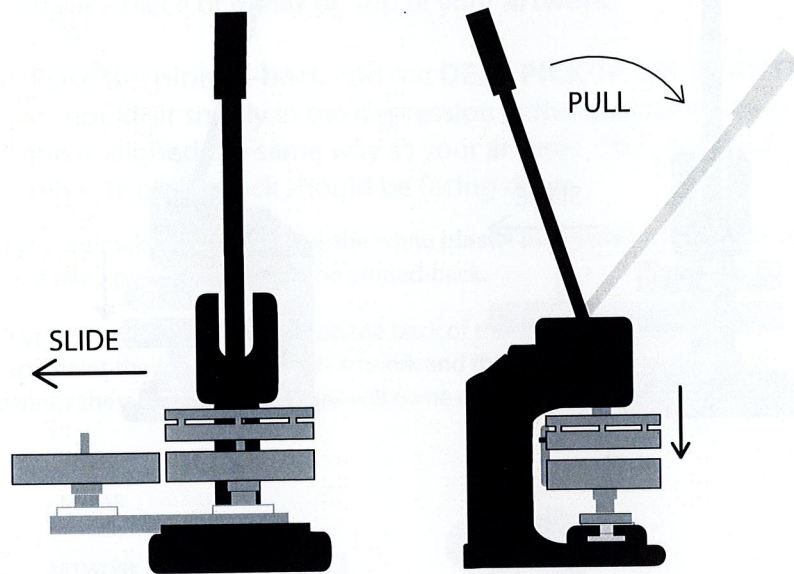

4. Slide the die table back to the left and remove your finished button. AND ENJOY!!

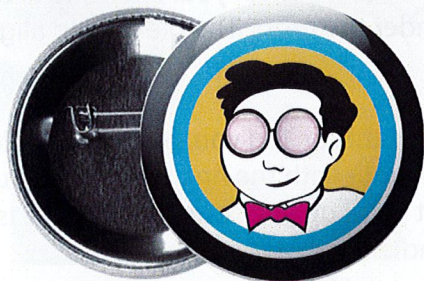

CREATING BUTTON ARTWORK

You can download templates to set up your own button artwork and find lots of other tips and ideas at:

thebuttonguy.net

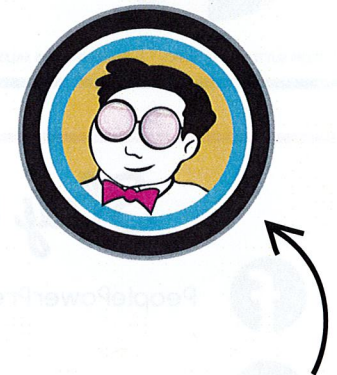
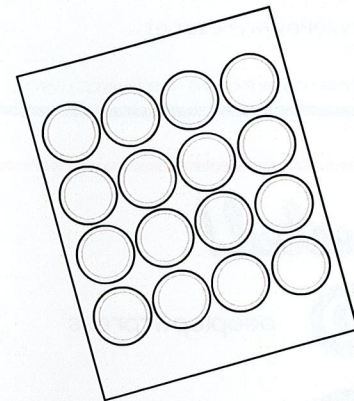

You can set up multiple buttons on one 8.5 x 11" size sheet using the downloadable templates.

Use the outer line on the template as a guide to cut out your artwork.

Try making buttons out of different materials!



Printed Artwork



Patterned Paper



Pictures from magazines or books

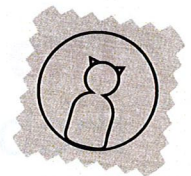

Even some fabrics!



People Power Press

#1 for Button Making



PeoplePowerPress.org



PeoplePowerPress.net

CUSTOM BUTTONS AND MERCH • BUTTON MACHINES SALES AND RENTALS • DIY SUPPLIES • CUSTOM PACKAGING • DESIGN SERVICES • EVENTS

Stay Connected!



PeoplePowerPress



peoplepwrpress



PeoplePowerPress



peoplepowerpress

Got a question about button making?

ask

The Button Guy

thebuttonguy.net



buttonguy



@button_guy